

BC 950 Dolphin Stainless Steel Touch Free Soap Dispenser

User Manual

Please read carefully before use



(1)USER'S GUIDE

PLEASE REFER TO THE " CONSTRUCTION DIAGRAM" & " PARTS LIST" in the reverse side.

- A. Battery operated DISPENSER. Use "C" type ALKALINE BATTERY 1.5V, 3pcs
- B. DIMENSION of DISPENSER 262(H) X 108(W) X 105(D) mm.
- C. CAPACITY OF **CONTAINER** (no.9) 800CC
- D. BATTERY LIFE: 10,000 cycles or 1 year.
- E. **POWER TURNS ON AUTOMATICALLY AFTER THE HOUSING (no.7) IS CLOSED.**
POWER TURNS OFF AUTOMATICALLY AFTER THE HOUSING (no.7) IS OPENED.
- F. INDICATOR GREEN SIGNAL LIGHT. It means "**IN USE**" & "**DISPENSING**"
FLASHING RED SIGNAL LIGHT. It means **BATTERY ARE LOW.** To remind you to change the BATTERY AS SOON AS POSSIBLE.
- G. If the DISPENSER does not work, please refer to the **INSTALLATION GUIDE** and check the following points.
 - G1 Is there enough LIQUID SOAP?
 - G2 Is the BATTERY charged? (no.6)
 - G3 Is there another object obstructing the SENSING RANGE?
 - G4 Are the **PLASTIC PIPE CONNECTORS** (no.10), the **PLASTIC PIPE** (no.11) and the **NOZZLE** (no.12) in the correct position?
 - G5 Has the **LID** (no.8) been removed?
 - G6 SENSING RANGE. The SENSING RANGE should be at 6 cm for HANDS (not for DISHES).
Please use a tiny little screw driver to turn the **ADJUSTER OF SENSING RANGE** (no.2)
CLOCKWISE TO INCREASE THE SENSING RANGE
COUNTER CLOCKWISE TO REDUCE THE SENSING RANGE
THE MANUFACTURER HAS FIXED THE SENSING RANGE AT 6CM FOR HANDS (NOT FOR DISHES)
You'd better not change the sensing range.
- H. If you would like to remove the DISPENSER. Please take out the battery and put the LID on the container tightly to stop dispensing.
- I. BEST DESIGN
You can remove and rinse the container assembly if parts numbered 9, 10,11 or 12. are blocked by something.

(2)INSTALLATION GUIDE

(PLEASE REFER TO THE "CONSTRUCTION DIAGRAM" & "PARTS LIST" on the reverse side.)

Please proceed the following procedures to install the AUTOMATIC SOAP DISPENSER.

- A. Nothing is allowed within 20 cm from the NOZZLE (no.12)
 - B. Two options for installation.
 - B1 Hang the DISPENSER. You can find two holes (no.13) on BACK PLASTIC PLATE (no.14) or
 - B2 Stick on the wall.
- By using the prepared **rubberized fabric** on the **BACK PLASTIC PLATE** (no.14)
Warning: Clean the wall before you stick the dispenser.

AFTER 10 HOURS. Please continue the following procedures if you're using the second method.

- C. Check the **BATTERY ASSEMBLY** (no.6)
Are the batteries new and powerful enough? (Use "C" type ALKALINE BATTERIES 1.5V, 3 pcs.)
Are the batteries installed correctly?
- D. Two options for liquid soap:
 - D1: Remove the **CONTAINER** (no.9). **CONTAINER** can be replaced by **SOAP CARTRIDGE**.
(You can find and purchase it from the supermarket) or
 - D2: Remove the **LID** (no.8) only, then fill the liquid soap into the **CONTAINER** (no.9)
Warning: The viscosity of liquid soap must be: 1 ~ 3,000 cps. It is normal liquid soap,
(You can find it in the supermarket.)
After procedure "D2", please throw away the **LID** (no.8)
Or, if you want to put the **LID** (no.8) on the **CONTAINER** (no.9), please don't turn the **LID**, too tightly, because flowing air is necessary inside the **CONTAINER** (no.9) for dispensing.
- E. Check the parts numbered 10, 11, 12 to make sure their positions are correct.
- F. Check the SENSING RANGE. The manufacturer has fixed the SENSING RANGE at 6 cm for HANDS (not for DISHES). Please don't change the SENSING RANGE.

(3) CONSTRUCTION DIAGRAM

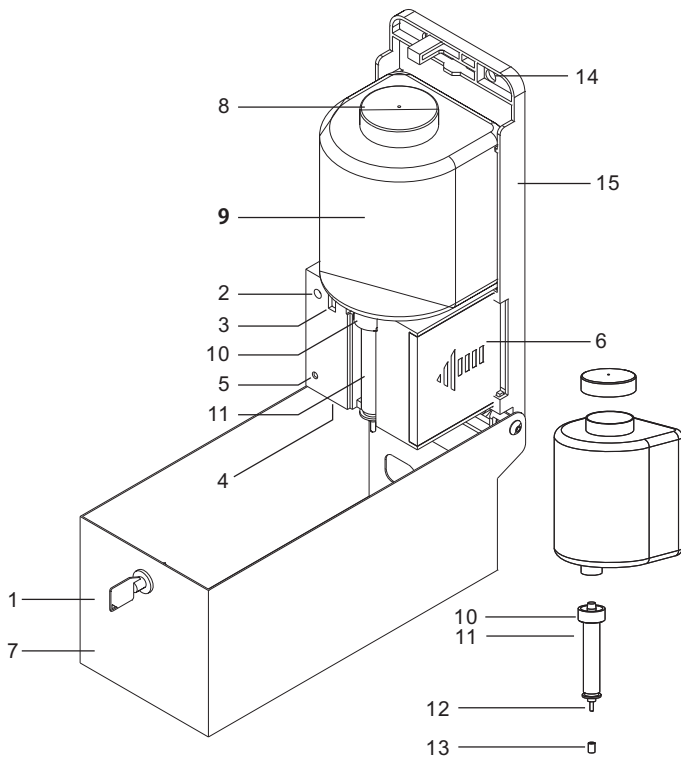

(4) PARTSLIST

PARTS NO.	DESCRIPTION
1.	SECURITY KEY
2.	ADJUSTER OF SENSING RANGE
3.	COVER INTERLOCK SAFETY SWITCH
4.	SENSOR ASSEMBLY
5.	LED INDICATOR FOR LOW BATTERY
6.	BATTERY ASSEMBLY
7.	HOUSING

CONTAINER ASSEMBLY:

- 8. TANK COVER
(WARNING: REMOVE LID AFTER INSTALLATION)
- 9. SOAP TANK
- 10. CONNECTOR between PLASTIC PIPE and container
- 11. PLASTIC PIPE
- 12. NOZZLE
- 13. NOZZLE CAP

FOR INSTALLATION:

- 14. TWO HOLES (FOR HANG UP THE DISPENSER)
- 15. BACK PLASTIC PLATE

(5) SUGGESTED INSTALLATION POSITION

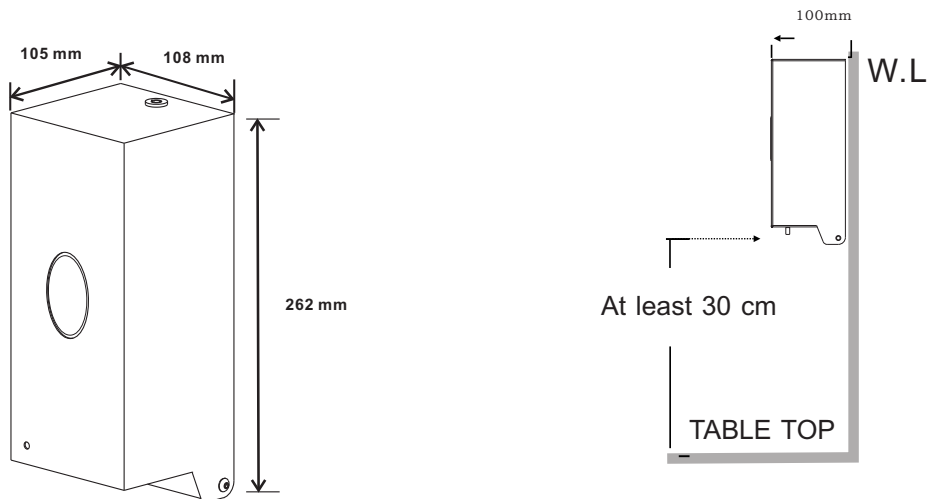

DISTANCE : At least 30 cm for TABLE TOP.
Otherwise the DISPENSER will keep dispensing.

SOAP DISPENSER MOUNTING TEMPLATE

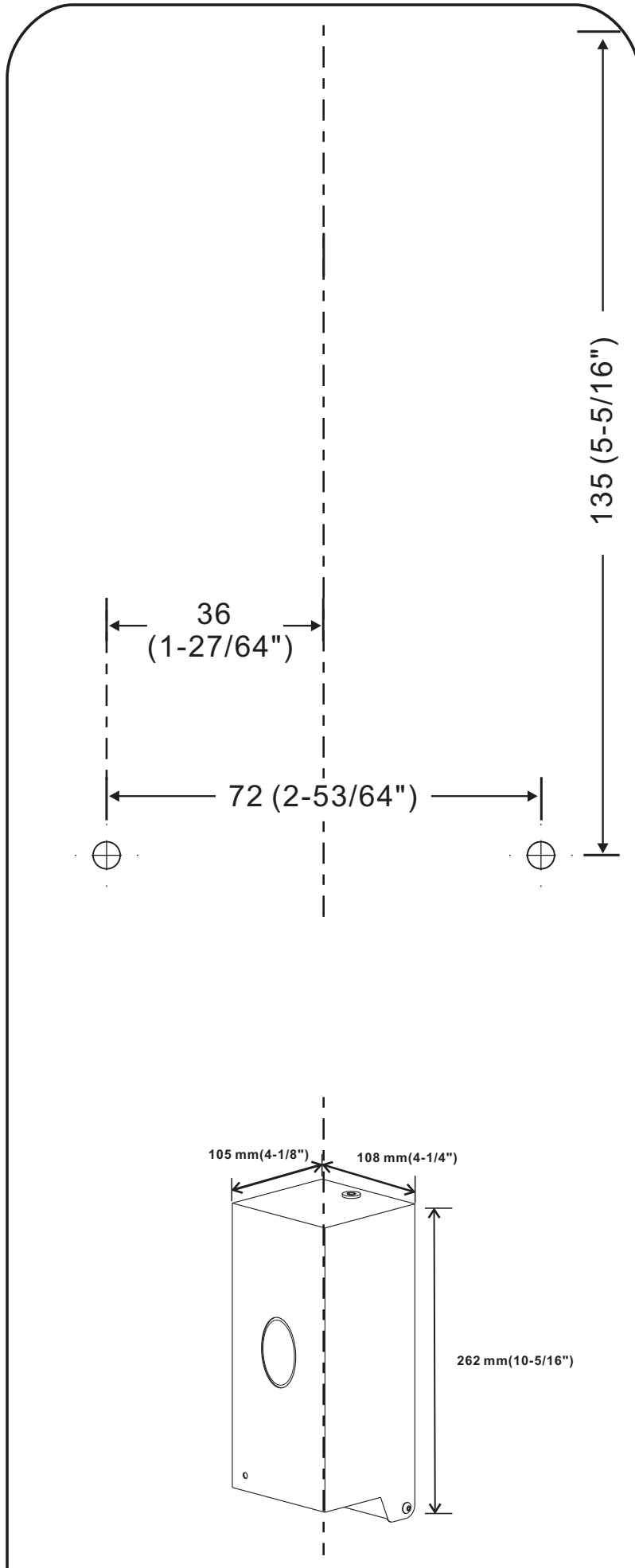

Bell-Chem Products Company
Haywood Way, Hastings, TN35 4PL
Tel: 01424 202224
info@dolphindispensers.co.uk
www/dolphindispensers.co.uk